



CASH Special Captive Bolt Stunner Product Data Sheet

Key Features ◀

Product Diagram ◀

Safe Operating Instructions ◀

Cleaning and Maintenance ◀

Trouble Shooting and Servicing ◀

Parts List ◀



**DO NOT ATTEMPT TO USE THIS STUNNING TOOL UNTIL YOU
HAVE READ AND UNDERSTOOD THESE INSTRUCTIONS**

Manufactured by Accles & Shelvoke Ltd

Selco Way, Off First Avenue, Minworth Industrial Estate, Sutton Coldfield, West Midlands, B76 1BA ENGLAND

Tel: +44 (0) 121 313 4567 Fax: +44 (0) 121 313 4569 Web: www.acclesandshelvoke.co.uk

Key Features

CASH Special Captive Bolt Stunner

The CASH Special Captive Bolt Stunner is a conventional pistol style trigger operated tool. Universal in its application the CASH Special Captive bolt stunner is available as a standard and heavy duty in both .22 and .25 calibre, making the tool suitable for use on small animals to large bulls.

PRODUCT CODE	.22 Calibre 4100R .25 Calibre 4121R .22 Calibre Heavy Duty 4000
CALIBRE	.22 .25
USE ON	Cattle, Pig, Sheep 
POWERLOADS	Use in Standard .22 CASH Special: CASH .22 PINK 1.25 Grain for small animals CASH .22 PURPLE 2.5 Grain for average size cattle and pigs CASH .22 GREEN 3 Grain for heavy animals and bulls
	Use in Heavy Duty .22 CASH Special: CASH .22 PINK 1.25 Grain for small animals CASH .22 PURPLE 2.5 Grain for average size cattle and pigs over 100KGs CASH .22 GREEN 3 Grain for heavy animals and bulls CASH .22 RED 4 Grain for very heavy cattle and bulls
	Use in .25 CASH Special: CASH .25 BLUE 3.5 Grain for all heavy animals

The CASH Special is part of the CASH range of stunners manufactured by Accles & Shelvoke.

CASH stunners are in use all over the world for in many varied situations from on-farm casualty slaughter to both small and large meat plants with automated production lines operating as high as 450 cattle per hour. The CASH stunner renders the animal instantly and irreversibly insensible to pain prior to slaughter, eliminating stress and suffering, improving meat quality and throughput, resulting in increased profits.

Renowned for its quality, durability and safety the CASH Special Captive Bolt Stunner is an extremely effective tool with the following features:

- ▶ Conventional pistol style trigger operated
- ▶ Universal in application from large bulls to small lambs, with varying power load strengths
- ▶ Well balanced, comfortable ergonomically designed handle
- ▶ 'Rolling Block' firing mechanism provides effective safety, requires two positive actions to fire
- ▶ Automatic bolt return
- ▶ Cash Special Captive Bolt Stunner is available as a standard tool in .22 or .25 calibre
- ▶ A heavy duty model is available with heavy cartridge - Red Strength

Product Diagram

CASH Special Captive Bolt Stunner

⚠️ WARNING

Pushing firing block to its forward position after loading will allow stunner to fire when trigger pulled, or if stunner is dropped or mishandled. Push firing block forward only immediately at the point of firing.

⚠️ WARNING

At all times, never point the muzzle towards any part of the body. To load or unload, hold as shown below with fingers clear of trigger.



SERIAL NO.
Quote when contacting manufacturers or your Cash distributor.

POWERLOAD
Quote batch No. on carton in event of complaint.

TRIGGER
Pull to fire stunner.

MUZZLE

⚠️ WARNING

Never immerse stunner in water to cool.

⚠️ WARNING

Never point muzzle at anything you do not intend to shoot.

⚠️ WARNING

Do not operate without safety glasses and ear protection.

Do not point in the direction of body or allow hands in front or near muzzle at any time. Take care when loading/extracting powerload

BOLT

Sometimes called pin, plunger or rod. Maximum bolt extension is 4 3/4" (121mm). Never hold stunner within 4 3/4" (121mm) of walls, stunning pen or anything you do not intend to shoot.

POLEAXE END

Re-sharpen by reoning using countersink tool. Do not grind outside diameter.



Safe Operating Instructions

CASH Special Captive Bolt Stunner

PULL BACK HAMMER AND FIRING BLOCK

The action of pulling back the firing block will operate the extractor and partially lift a spent (fired) powerload. See (5) extraction.



WARNING

At all times never point muzzle end of barrel towards your body or any other person.



WARNING

If in any doubt whether or not power load has been fired, treat as a live powerload. (See removal of unfired powerload). If misfire has occurred. See 'safe misfire removal'

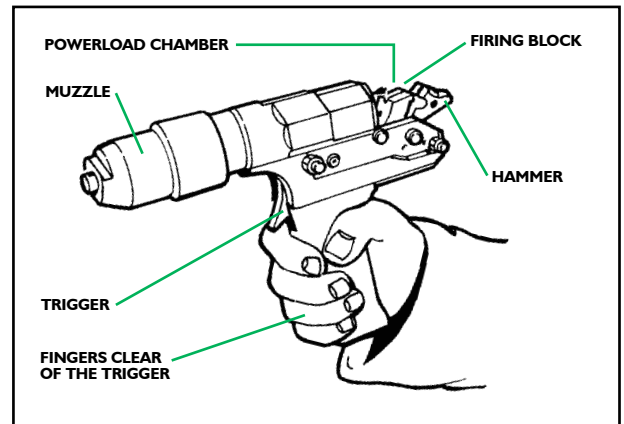

2 LOADING

Before inserting powerload into chamber of breech, make sure bolt is fully retracted as shown. If not, does not use as stunning power will be reduced. (See cleaning daily to rectify).



WARNING

Only use the correct grade of CASH powerload bearing the "AS" or "E" headmark.

PLEASE REFER TO POWERLOAD SELECTION TABLE SHOWN ON PAGE 1

It is a condition of Accles & Shelvoke's product liability insurance, that only CASH powerloads in CASH carton and bearing approved headmarks must be used in stunners manufactured by them. It follows therefore, that no liability whatsoever can be accepted for any claim, including injury should any other brand of powerload be used.



WARNING

Where powerloads other than these are used, Accles & Shelvoke will not be responsible for:

1. The safety of the operator.
2. The humaneness of the stun.
3. The correct operation of the stunner.
4. The premature failure of parts.

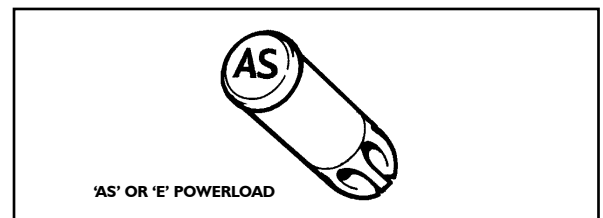
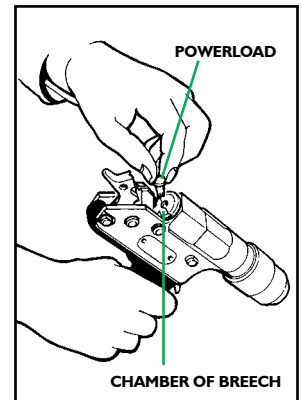
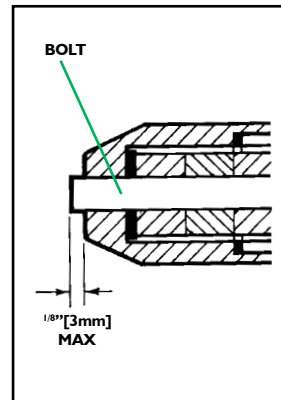

WARNING

Powerloads must be stored in cool, dry conditions. Exposure to excessive amounts of moisture may affect their performance.

3 MAKE READY FOR FIRING

Immediately before firing, push firing block forward against the breech face.



WARNING

The CASH Special will fire if dropped or the trigger is pulled.



WARNING

Keep fingers clear of trigger until immediately before firing.

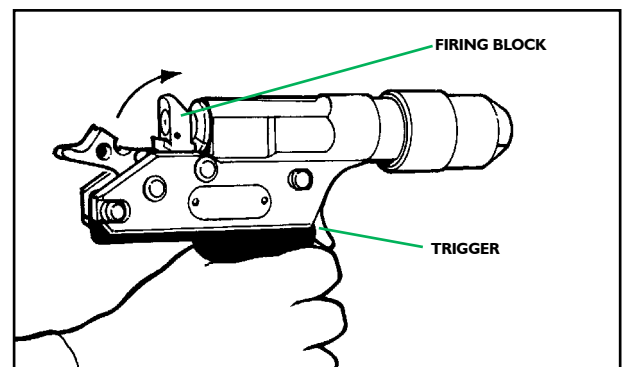

4 FIRE

Place muzzle firmly on animal's head, in the recommended position shown below. Pull trigger to fire. The action of positioning should be smooth, fluid and accurate, with firing immediate, with the minimum delay. Do not attempt to fire whilst the animal is moving its head.

⚠️ WARNING

Never leave a loaded stunner unattended (See removal of unfired powerload.)

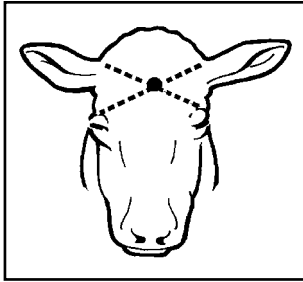

CATTLE, CALVES

Place muzzle on spot indicated, in the middle of the forehead at the crossing point of two imaginary lines drawn between the eyes and the centre of the base of the opposite horns.

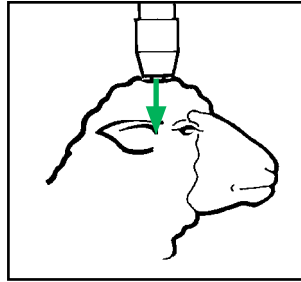
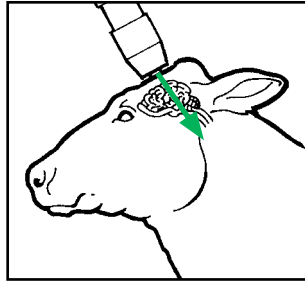

SHEEP

For hornless sheep, place muzzle in the centre of the top of the head. For horned sheep and goats, the muzzle should be placed behind the ridge between the horns, centrally aimed towards the base of the tongue.

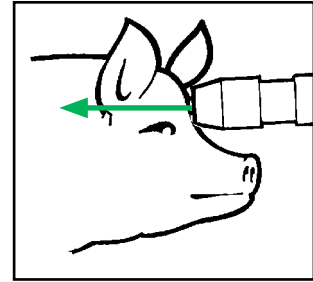

PIGS

Place muzzle about $\frac{3}{4}$ " (20mm) width above the eyes, halfway across the forehead, aiming up slightly.

5 EXTRACTION

Pull back the hammer and then the firing block, which will operate the extractor and partially lift the spent case ready for complete removal using finger and thumb. The stunner is now ready to receive the next powerload (see 2 Loading).

REMOVAL OF UNFIRED POWERLOAD

It is sometimes necessary to remove an unfired powerload (live) from the chamber at the end of a shift for example, or if the CASH Special is to be left unattended. Pull back hammer and follow instructions as detailed under 5 Extraction, but taking great care to handle powerload gently and return it to its container.

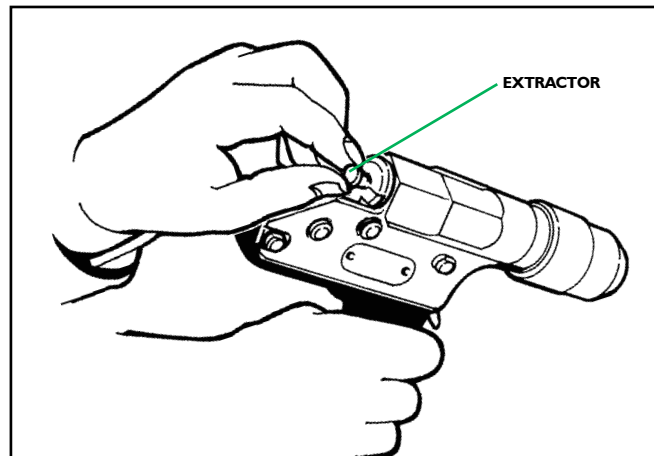

⚠️ WARNING

If unfired powerload is stuck in the chamber or the extractor fails to operate, do not attempt to remove using a knife or similar tool. Return stunner to maintenance department, warning them that an unfired (live) powerload is stuck in the chamber, and with hammer and firing block pulled back, see 1 "Pull back hammer and firing block".

⚠️ WARNING

SAFE MISFIRE REMOVAL

If stunner fails to fire, a delayed firing may occur during or after extraction. Keep CASH Special muzzle away from your body or any other person. Wait 30 seconds before pulling back hammer and firing block to extract the powerload. After 30 seconds, remove powerload and drop into a metal container filled with water. Do not attempt to re-use misfired load. Powerloads fire by crushing head, so do not crush, prise or strike or use excessive force. Always wear safety glasses and ear protectors. If stunner misfires more than once, it should be withdrawn from use and returned to the maintenance department for investigation.

⚠️ WARNING

It is a condition of Accles & Shelvoke's product liability insurance, that only CASH powerloads in CASH cartons and bearing "AS" or "E" headmarks must be used in stunners manufactured by them. It follows therefore, that no liability whatsoever can be accepted for any claim, including for injury, should any other brand of powerload be used.

Cleaning and Maintenance

CASH Special Captive Bolt Stunner

Guidance on daily and weekly cleaning and consumable parts maintenance. Please refer to Repair Manual for detailed instructions on parts replacement.

DO NOT ATTEMPT TO USE THIS STUNNING TOOL UNTIL YOU HAVE READ AND UNDERSTOOD THESE INSTRUCTIONS



WARNING For test firing or the removal of unfired powerloads, always wear safety glasses and ear protection. Before ANY action, check to see that powerloads has not been left in chamber.

Cleaning - Daily

- (1) Pull back hammer and ensure that stunner is not loaded.
- (2) Unscrew the muzzle cap from the barrel. If too tight, hold on flats on muzzle in a vice fitted with soft jaws and unscrew, using the hand grip moulding as a lever.
- (3) Withdraw the bolt assembly from the barrel, it should be possible to remove the bolt from the barrel by hand. If not, grip the barrel in a vice fitted with soft jaws. Pull back the hammer and firing block and insert the push rod into the powerload chamber and gently tap out bolt.
- (4) Wipe inside of barrel with barrel brush cleaner to remove the day's soft powder and sludge. Carefully insert breech cleaner as shown opposite. Note, these operations are best done when the barrel is still warm after use and before powder solidifies. Young's 303 fluid can be used if powder is hard and difficult to remove.
- (5) Remove washers and recuperator sleeves from the bolt and with wire wheel or brush, remove carbon from bolt, wiping with a lightly oiled rag when clean. Wipe any carbon sludge from recuperator sleeves and washers and examine for wear.

EXAMINE PLASTIC WASHERS AND RECUPERATOR SLEEVES

- (A) Stop washer - colour red, item No. 6.**
There is one of these washers fitted at the poleaxe end of the bolt, against the muzzle cap. This protects the recuperator sleeve next to it from extruding through the clearance between the bolt stem and the muzzle bore. Once washer shows wear in bore or out side diameter, replace, otherwise rapid sleeve wear will result.
- (B) Flange washer - colour blue, item No. 7.**
This washer is placed behind the last recuperator sleeve against the bolt flange. Again, as soon as this shows wear on the outside edge, replace or rapid sleeve wear will result.
- (C) Recuperator sleeve, item No. 8.**
A full set comprises 8 sleeves. Number 1 and number 8 on the bolt will be the first to show signs of wear. They should be moved into a middle position, so that they all wear evenly. Once they become badly worn and start to fray, they should be replaced. A full set should last approximately 5000 shots, provided stop and flange washer are kept in good condition.

DO NOT NEGLECT THE WASHERS OR SLEEVES OTHERWISE STUNNING POWER WILL BE LOST AND THE BOLT WILL STICK IN THE HEAD.

- (D) Muzzle barrel washer, item No. 9.**
Replace if broken, torn or ragged. In this condition or if missing, rapid wear to recuperator sleeves will result.

RE-ASSEMBLE

Wipe all steel parts with an oily rag. Do not over oil and use only CASH pistol oil. Do not put oil into the powerload chamber, as this can cause misfiring.

Cleaning - Weekly

TO BE CARRIED OUT ONCE A WEEK, IN ADDITION TO DAILY CLEANING.

The enlarged diameter inside the barrel at the breech end, described as the 'undercut', must be kept from filling with powder, otherwise bolt return and stunning power will be affected. As well as cleaning the undercut, the undercut cleaner, will clean the front face of the breech block at the same time.

- (1) Grip the undercut cleaner in a vice in a vertical position (see diagram below).
- (2) Slide the barrel down the cleaner until the breech face contacts.
- (3) Apply sideways pressure to the barrel so that the cleaner enters the undercut. Maintaining this pressure, rotate the barrel backwards and forwards two or three times. turn the barrel through 90 degrees and repeat. Continue this process until the undercut has been cleaned completely. Check the vent hole is not blocked.

Cleaning Tools

ITEM NO.	PART NO.	DESCRIPTION	NO PER SET
1	4107	Breech Cleaner Assembly	1
2	5645	Barrel Bush	1
3	5647	Handle Brush Cleaner	1
4	4191	Undercut Cleaner	1
5	4119	Push Rod	1
6	4136	Spanner	1
7	4187	CASH Pistol Oil	1
8	4192	COPASLIP Thread Grease	1
9	6076	Youngs 303 fluid	1

Please note items 1-6 are included with the Stunner when purchased, items 7-9 are additional extras (last three are all extras on all the stunners)

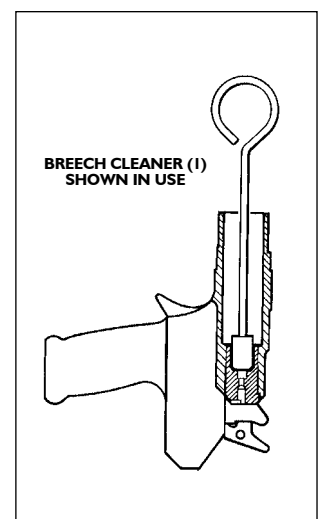
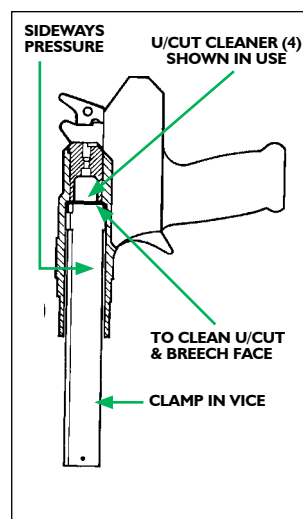

EXTRACTION OF STUCK, UNFIRED OR MISFIRED POWERLOAD



Great care must be taken in removing unfired or misfired powerloads stuck in the chamber. (For misfires, see safe misfire removal, page 4) Follow instructions set out below.

Unscrew muzzle cap and remove bolt assembly. Grip barrel in soft jaws in a vice and gently push powerloads out, using push rod, through the chamber.



Always wear safety glasses and ear protection for this operation.

MISFIRES CAN BE CAUSED BY:

- (1) Water or oil contaminated powerloads.
- (2) Weak or broken sear spring (item No. 19)
- (3) Worn or damaged powerload chamber.
- (4) Worn or damaged firing pin (item No 32).
- (5) Worn or damaged firing block (item No. 10), or hammer (item No. 21).
- (6) Oil in powerload chamber.

BOLT STICKING IN ANIMAL'S HEAD AND/OR STUNNER POWER LOSS

- (1) Ensure that stunner is being used with correct power load for type and weight of animal to be stunned, see page 3.
- (2) Barrel, breech or bolt requires cleaning, including undercut.
- (3) Sleeves and/or washers require replacement.
- (4) Bolt bent or damaged or re-sharpened by grinding outside diameter.

If in doubt and you require further advice and information please contact Accles & Shelvoke direct or you're local Distributor.

Accles & Shelvoke Ltd, Selco Way, Off First Avenue,
Minworth Industrial Estate, Sutton Coldfield, West Midlands,
B76 1BA ENGLAND

Tel: +44 (0) 121 313 4567 Fax: +44 (0) 121 313 4569

Servicing

Accles & Shelvoke provide a comprehensive service and repair facility where customers can have their CASH stunner serviced by our highly trained engineers:

- ▶ The service involves the tool being stripped, cleaned and re-assembled bringing the stunner back to working order.
- ▶ Service and repair facility is generally open to UK customers, overseas customers are advised to contact their local distributor.
- ▶ Customers are advised to contact Accles & Shelvoke direct on + 44 (0) 121 313 4567 to make arrangements to return the tool for service or repair.
- ▶ Quotation will be provided on inspection of the tool, listing service charges and replacement parts required.



Parts List

CASH Special Captive Bolt Stunner

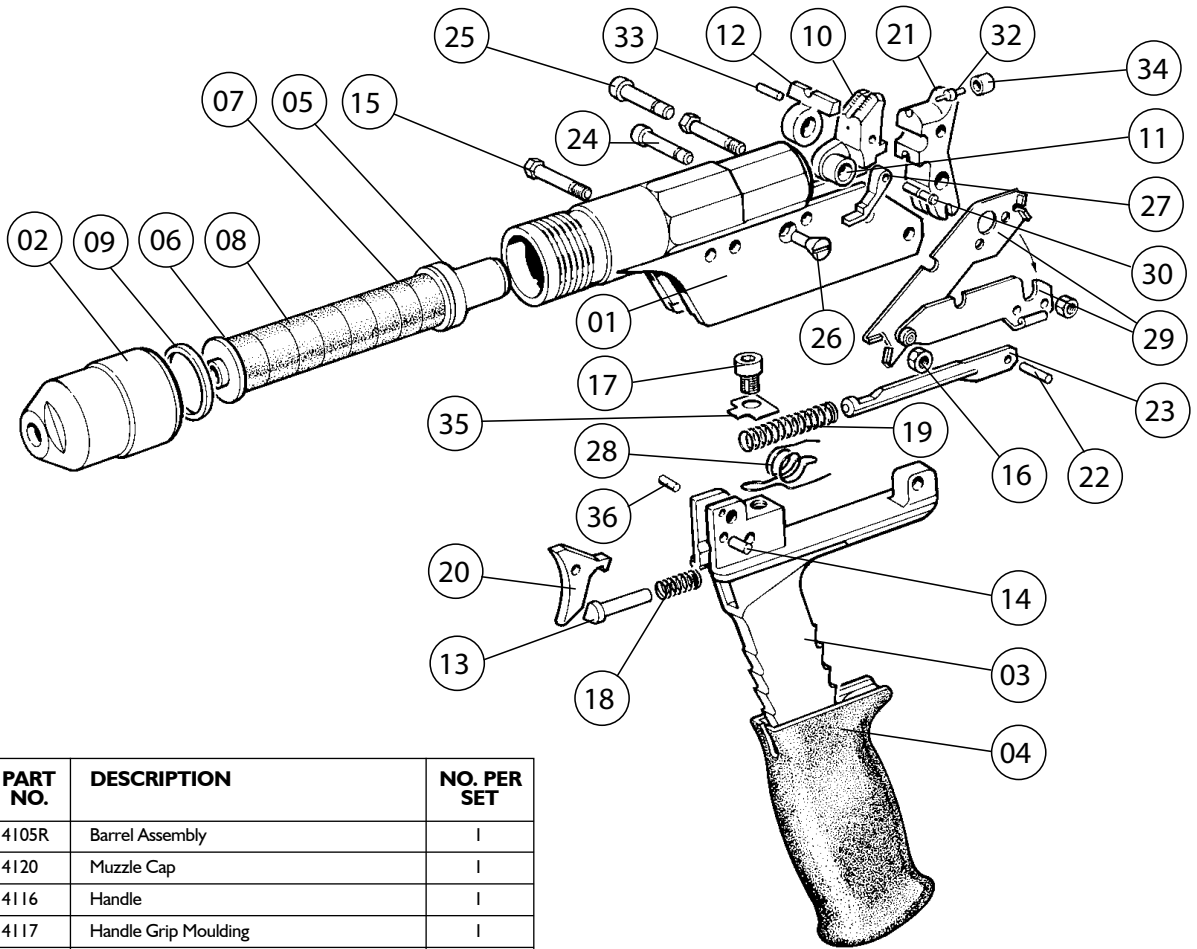

ITEM NO.	PART NO.	DESCRIPTION	NO. PER SET
1	4105R	Barrel Assembly	1
2	4120	Muzzle Cap	1
3	4116	Handle	1
4	4117	Handle Grip Moulding	1
5	4118	Bolt	1
6	5369	Stop Washer	1
7	5403	Flange Washer	1
8	5376	Recupertor Sleeve	8
9	4115	Muzzle / Barrel Washer	1
10*	4139	Firing Black Assembly	1
11	4140	Firing Black Bush	1
12*	4141	Extractor	1
13	4145	Trigger Plunger	1
14	4146	Trigger Axis Pin	1
15	4147	Handle / Barrel Bolt	2
16	4159	Nuts for Item 15	2
17	4148	Spring Screw	1
18	4149	Trigger Spring	1
19	4150	Sear Rod Spring	1
20	4151	Trigger	1
21*	4152	Hammer	1
22*	4153	Sear Rod End Pin	1
23	4154	Sear Rod Assembly complete with pin	1
24	4156	Firing Block Pivot	1
25	4157	Hammer Pivot	1
26	4158	Extractor Stop Screw	1
27	4160	Pawl	1
28	4161	Extractor Spring	1
29	4164	Locking Plate Assembly	1
30	4165	Pawl Pivot	1
31#	4166	Firing Pin Assembly items 32,33 &34	1

ITEM NO.	PART NO.	DESCRIPTION	NO. PER SET
32	4167	Firing Pin	1
33	4168	Firing Pin Rivet	1
34	4170	Firing Pin Back Bush	1
35	4171	Lock Washer	1
36	41709	Trigger Stop Pin	1

CASH SPECIAL HEAVY DUTY PARTS:
Heavy Duty parts and for use in the Heavy Duty
CASH Special model only:

ITEM NO.	PART NO.	DESCRIPTION	NO. PER SET
37#	4030	Barrel Assembly for Heavy Duty	1
38#	4024	Bolt for Heavy Duty	1
39#	4012	Sear Rod for Heavy Duty	1
40#	4010	Hammer for Heavy Duty	1
41#	4016	Sear Rod End Pin for Heavy Duty	1
42#	4018	Sear Rod for Heavy Duty	1

* See separate Repair Manual for detailed instruction on fitting
Part not illustrated